

# MANISCOPIC

## MVT 628 TURBO





- Max. lift height : 6.30 m
- Capacity : 2800 kg
- Overall width/Overall height : 1.99 m
- Diesel engine : 101 HP/74.5 kw
- Hydrostatic transmission

*Varioshift*

## MVT 628 TURBO

 **Lift capacity** .....2800 kg  
at 500 mm from forks heels.

 **Lift height** .....6.30 m

 **Tyres**  
16/70 - 20 10 PR

 **Forks (mm)**  
Length .....1200  
Width x thickness .....125 X 45  
Maximum distance between forks .....1260  
Carriage rotation .....135°

 **Multidisc brakes - hydraulically assisted on front axle**

 **PERKINS Engine**  
Type 10044 C.44 T .....4 cyl. - 4400 cm<sup>3</sup>  
Power .....101 HP/74.5 kw (ISO/TR 14396)  
Maximum torque .....412 Nm at 1400 rpm  
Direct Injection  
Water Cooling

 **Hydrostatic transmission**  
Electro-hydraulic reversing shift  
Maximum travel speed .....33 km/h

 **Hydraulics**  
Gear pump .....80 l/mn - 235 bars  
Steering pump .....170 bars/Load sensing

 **Capacities**  
Cooling system .....16 l.  
Engine oil .....8.1 l.  
Hydraulic oil .....80 l.  
Fuel tank .....95 l.

 **Weight unladen (with forks)** .....5600 kg  
**Overall width** .....1.99 m  
**Overall height** .....1.99 m  
**Turning radius (outside wheels)** .....3.91 m  
**Overall length** .....4.43 m  
**Ground clearance** .....0.36 m  
**Drawbar pull** .....5700 daN

Reach at maximum height : 0.75 m

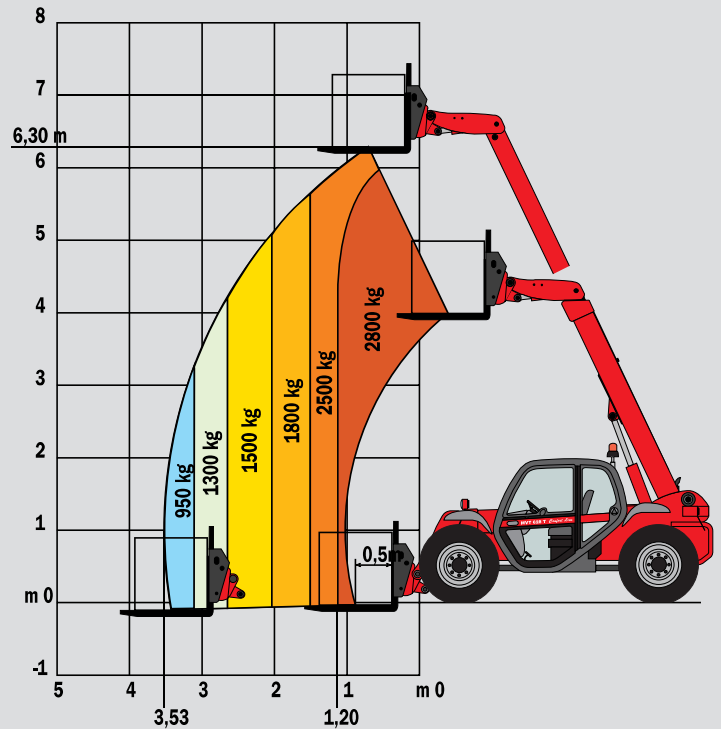

EN 1459 annexe B

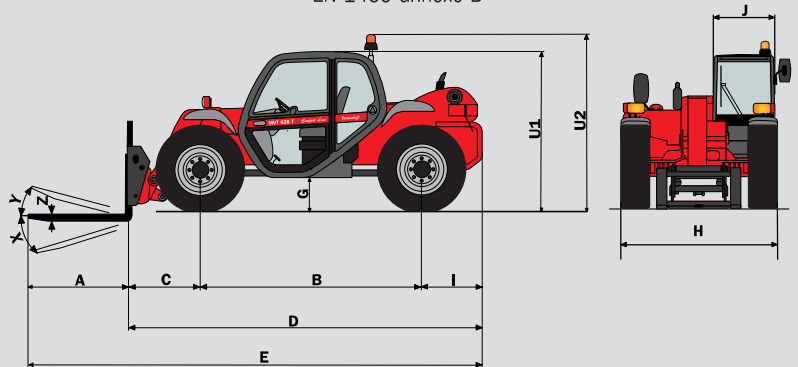

### MVT 628 T

A	1200
B	2750
C	930
D	4430
E	5630
F	1570
G	355
H	1990
I	750
J	910
K	1040
O	125
R	3450
S	7380
T	3500
U1	1990
U2	2240
V	4600
V1	1620
V2	3910
X	123°
Y	12°
Z	40

mm

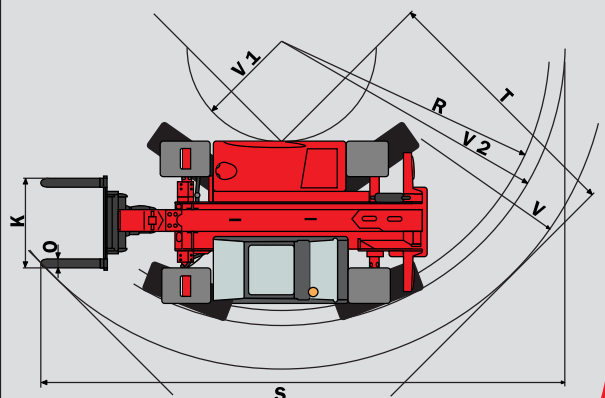

This publication in no way constitutes an offer and the company reserves the right to alter specification without prior notice. The MANITOU models presented in this brochure can be supplied complete with optional equipment attachments.

