

# TECHNICAL DATA

PAVER (TIER3)

BF 200 C-2



Greatest durability



Shorter set-up times



Exemplary efficiency

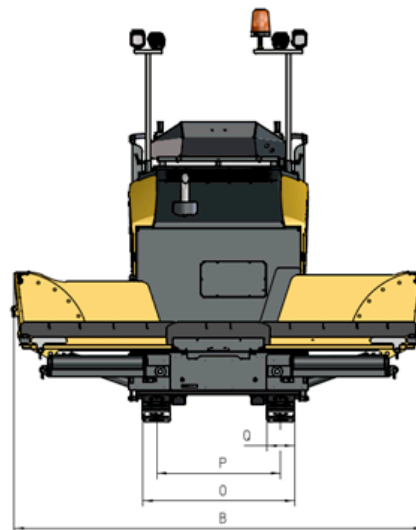
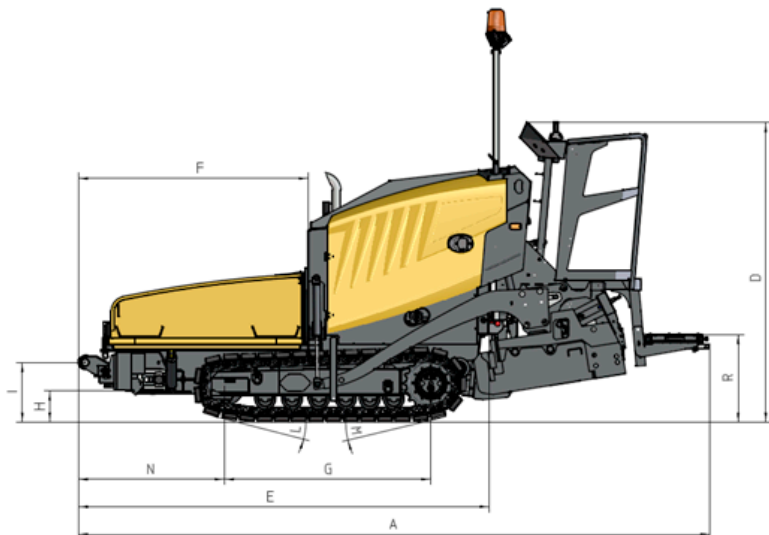

**Dimensions in mm**

	A	B	D	E	F	G	H	I	L	M	N	O	P	Q	R
<b>BF 200 C-2</b>	4600	2980	1995-2195	2986	1671	1500	228	433	14°	14°	1061	1100	900	200	458-658



Two level platform concept - best view without compromises.



Compact and agile - unique recipe for full flexibility.



Save up to 20 % fuel – demand-driven hydraulics – with BOMAG ECOMODE.



Heats up nearly 60 % quicker – unique MAGMALIFE heating system.

## Technical Data

## BOMAG BF 200 C-2

### Weights

Operating weight CECE ..... kg 6000

### Dimensions

Transport length ..... mm 4270

Transport width ..... mm 1300

Transport height ..... mm 1995

### Travel characteristics

Travel speed ..... km/h 0-4,5 variable

Working speed ..... m/min 0-29 variable

### Drive

Engine manufacturer ..... Kubota

Type ..... V3307-T

Emission stage ..... Stage IIIa / TIER3

Cooling ..... liquid

Number of cylinders /Displacement ..... cm<sup>3</sup> 4 / 3330

Performance ..... kW / hp 54,6 / 73,2

Speed ..... min<sup>-1</sup> 2200

Performance ECOMODE (1.570 min<sup>-1</sup>) ..... kW / hp 43,3 / 58,9

Performance ECOMODE (1.800 min<sup>-1</sup>) ..... kW / hp 48,6 / 66,1

### Hopper

Capacity ..... m<sup>3</sup> 2,0

Width (wings open)..... mm 2980

Width (wings close) ..... mm 1300

Length ..... mm 1400

Filling height (middle) ..... mm 433

### Conveyor

Number..... 1

Rotary speed..... m/min 33

Individual control ..... no

Reversing operation ..... Standard

### Auger

Number..... 2

Auger diameter ..... mm 300

Rotary speed..... min<sup>-1</sup> 87

Reversing operation ..... Standard

### Screed

Basic width retracted ..... mm 1100

Basic width extended..... mm 2000

Min. width with reduction skids ..... mm 400

Mat thickness ..... mm 200

Screed plate depth..... mm 250

Screed plate thickness..... mm 10

Heating ..... electric

Crown ..... % -2,0 ... +4,0

Tamper frequency (TV/V) ..... Hz max. 30 / n.a.

Vibration frequency ..... Hz max. 60

Basic weight (TV/V) ..... kg 790 / 700

Max. working width..... mm 3400

### Filling capacities

Fuel..... l 80

Hydraulic oil..... l 60

## Standard Equipment

### Operator compartment

- Dashboard protection
- Digital display for machine management
- SIDEVIEW with a double steering and travel joystick

### Tractor

- ECOMODE
- Push rollers
- Separate control of hopper wings
- 2 proportionally controlled and reversible wear-resistant cast augers; screw blades separately replaceable
- Rubber track pads

### Screed

- Screed temperature control
- Mechanical screed lock
- Crown adjustment
- Side control of auger/scrapper belts

### Other

- Tools
- Three phase Generator

### Hopper

- Viewing tunnel

## Optional Equipment

### Operator compartment

- Two platform concept

### Tractor

- Integrated cleaning kit
- Asphalt steam extraction
- Optional paint finish
- Biologically degradable hydraulic oil
- Hydraulic, height adjustable auger
- Track scraper
- Direction rod
- Ultrasonic sensors for auger control

### Screed

- Hydraulic crown adjustment
- S 200 extensions: 350 mm
- S 200 extensions: 600 mm
- MAGMALIFE Aluminium heating plates
- Heated side plates
- Reduction shoes

### Levelling systems

- L.C.S. Screed relief and traction increase system
- Height and cross-slope sensing by means of ultrasonic or mechanical sensors

### Other

- Fleetmanagement BOMAG TELEMATIC
- LED working lights
- Sunroof
- Joblink data interface

### Hopper

- Hydraulic side flap

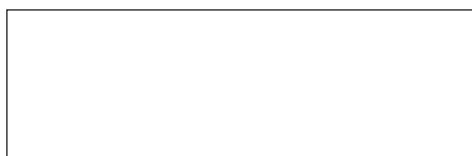





# SMALL IN SIZE, YET BIG ON RESULTS.

THE MINI PAVER BOMAG BF 200 C-2.





# MILLIONS OF KILOMETRES BEAR OUR SIGNATURE.

You build the finest roads so we can all make the quickest progress. And to ensure your rapid progress, we build the best machines. As a member of the leading international FAYAT group, we supply machines for all areas of road construction – from soil compactors, cold planers and recyclers through to asphalt rollers and pavers. For over 60 years, the history of our company has been synonymous with the history of road construction.

We are the driving force behind innovation that sets the pace for an entire industry. BOMAG has developed numerous new technologies such as ECOMODE to lower operating costs – or the most effective screed heating on the market: MAGMALIFE.

Our global network of experts and partners in over 150 countries will support you in the configuration of machines all the way through to providing solutions for the most challenging of tasks.

We owe our innovative strength to our more than 2,500 experienced and committed employees worldwide. A source of expertise that has made us the global market leader in this sector. Our unconditional commitment to quality is second to none: in product development and production, in the qualification of our employees, and in a service that guarantees optimum on-site support.

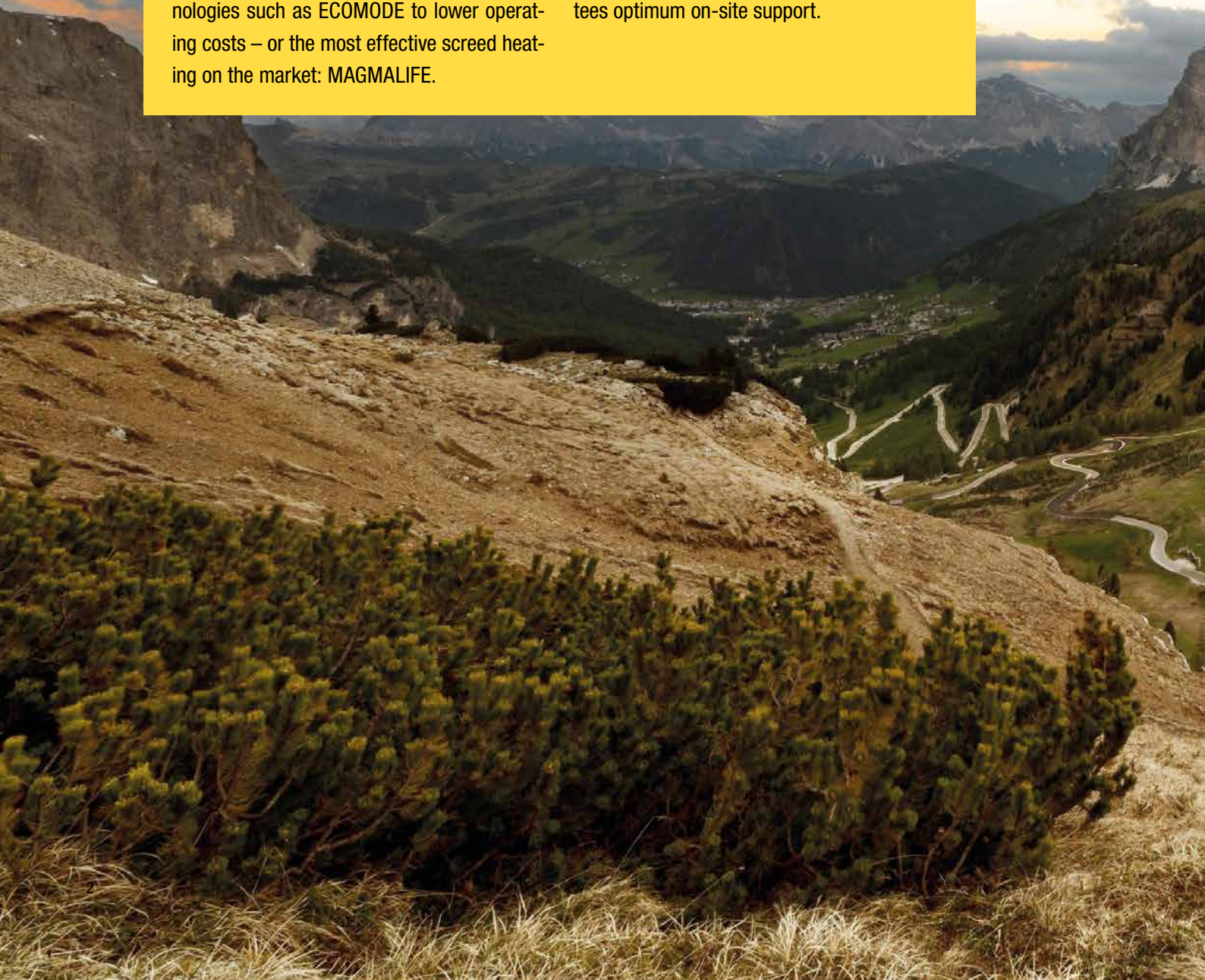









HIGHWAY PAVERS  
**BF 900 and BF 800**

UNIVERSAL PAVERS  
**BF 700 and BF 600**



# IT'S NOT THE SIZE THAT COUNTS!

Road construction is a complex task. That is why every BOMAG paver is systematically designed for efficiency. This also applies to the compact BF 200 C-2 mini paver, which comes into its own wherever space is at a premium: e.g. on narrow paths that border directly on walls or pass between buildings. Its high versatility makes it a first-class tool for inner-city applications on industrial sites, in gardening/landscap-

ing or in municipal operations. From a technological point of view, it offers everything that distinguishes BOMAG pavers in general: pioneering ergonomics, outstanding reliability and a perfect surface thanks to tamper/vibratory screed and MAGMALIFE. Its particularly attractive price/performance ratio makes the BF 200 C-2 a choice that pays off in the long run.



CITY PAVER  
**BF 300**

MINI PAVER  
**BF 200 C-2**



# GOOD JOB. ESPECIALLY THE DETAILS.

WHAT MAKES OUR BF 200 C-2 UNIQUE:

## FLEXIBLE LOADING

- By truck, wheel loader or excavator
- Use of hopper plates in confined spaces

## MAXIMUM LONGEVITY

- Sturdy design
- Highest quality
- Intelligent system layout
- Robust wheel or chain drives
- Robust screed construction

## COMPACT DIMENSIONS

- Weight < 6 t
- Minimal paving width of 1.1 m, as small as 0.4 m with a reduction shoe
- Transport width always < 2.5 m, even with screed extensions





## CLEVER OPERATING CONCEPT

- Height-adjustable control panel
- 2-platform concept
- Dual operation left/right
- One display for all important functions
- Best overview of hopper and screed
- Optimal view through viewing tunnel
- Well thought-out storage options



## FASTEST POSSIBLE HEAT-UP TIMES

- MAGMALIFE innovative screed technology\*
- Best results right from the start
- Uniform thermal image
- Hard-wearing screed plates for low maintenance costs



\*Optional

## SHORTER SET-UP TIMES

- QUICK COUPLING quick attachment system
- More flexibility on the construction site



## INTELLIGENT EFFICIENCY

- ECOMODE engine and hydraulic management
- Optimal performance with reduced fuel consumption



FOR MORE VERSATILITY.

## ACHIEVING GREAT RESULTS IN THE SMALLEST OF SPACES.

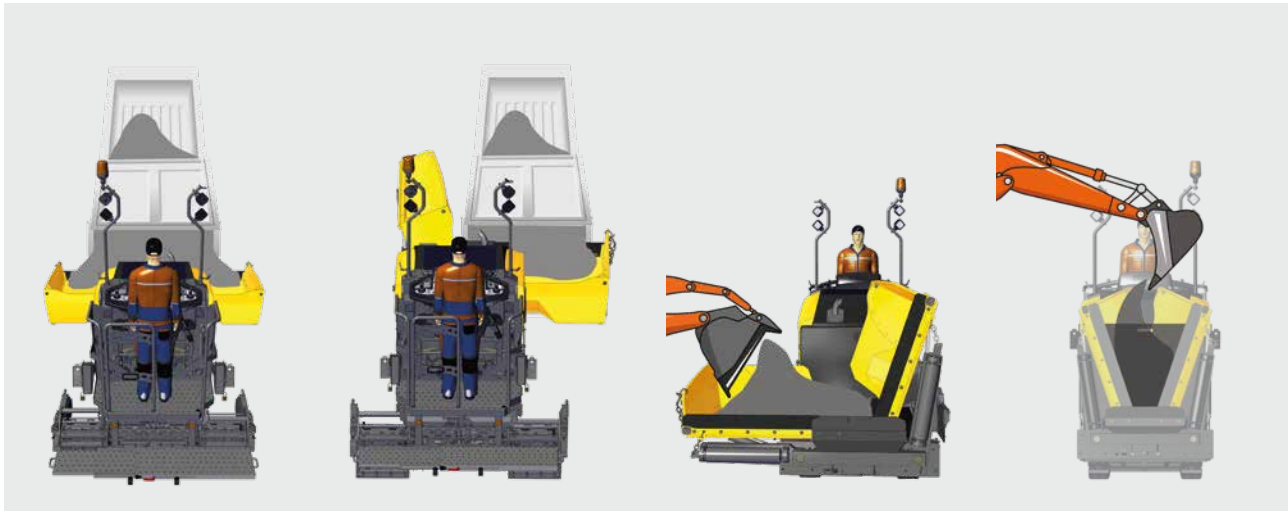

Loading by truck, wheel loader or excavator – all these options work well.

Maximum variability on the job: The BF 200 C-2 is always at home where flexibility is required. Whether loading is by truck, wheel loader or excavator – everything is possible. But this is not the only place where the BF 200 C-2 demonstrates its compactness. The BF 200 C-2 can be used in

paving applications where a minimum paving width of 1.1 m is required. From chain to chain, it even achieves a smaller width than that: This enables you to pave and manoeuvre easily in 1.2 m trenches. All for the best paving result in this class.



The BF 200 C-2 is in its element for paving widths of 1.1 m and above.



Transport width 1.3 m. Fits through any space that a 4.5 t forklift can pass through.



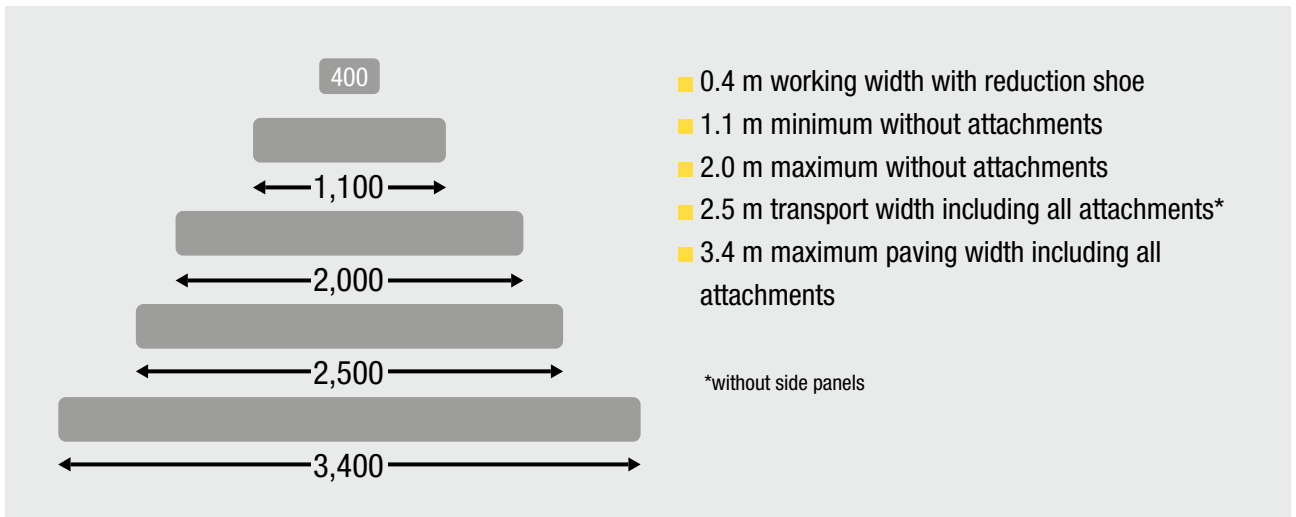

Under certain circumstances, transportation to the job site can prove to be a challenge. Not for the BF 200 C-2: Thanks to its compact dimensions, it can fit almost anywhere. At less than 2 m in height, even pedestrian un-

derpasses are no problem. With a transport width of less than 2.5 m, the BF 200 C-2 also fits on any truck, even with extensions attached to 3.4 m. Special permit? Not necessary.



Passes anywhere – even through a pedestrian underpass only 2 m high.



TYPICAL BOMAG: MAGMALIFE.

## A PAVER THAT HEATS UP QUICKER, FINISHES SOONER.

The right temperature is crucial in asphalt construction. With MAGMALIFE, we have redefined screed heating. All the screed plate heating rods are cast into one aluminium

block. Because of aluminium's excellent thermal conductivity, the heat-up time is significantly shorter. After just 20 minutes, the BF 200 C-2 reaches operating temperature



Surprisingly simple: heating system with monitored heating circuits.

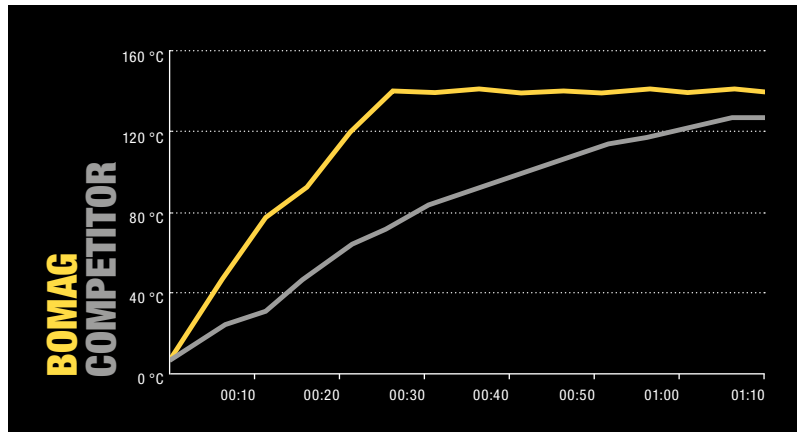

BOMAG compared to conventional electric screeds.



Perfectly protected: cast-in heating elements.



while ensuring even temperature distribution to the screed plates. Another advantage is the independent side plate heating. Experience precision work right from the start.

In addition to short heat-up times, MAGMALIFE excels with its long service life. The embedded heating elements resist the most adverse conditions, whether from vibration impacts or corrosion. The electrically heated screed side plates not only prevent bitumen sticking to them when

cold, but also prevent unwanted marks in the asphalt. This extends the screed's service life considerably, thus reducing maintenance costs. The interval for replacing the heating elements is increased from one to two years! Every part of this machine is designed for a high level of performance. This is also guaranteed by a generously dimensioned three-phase generator. Bring on your challenges: On the road, get set, go!



Speed is not a mystery, but the result of creative, user-oriented engineering. The new MAGMALIFE screed heating is ready for operation three times faster than conventional systems.

Heatable side plates.

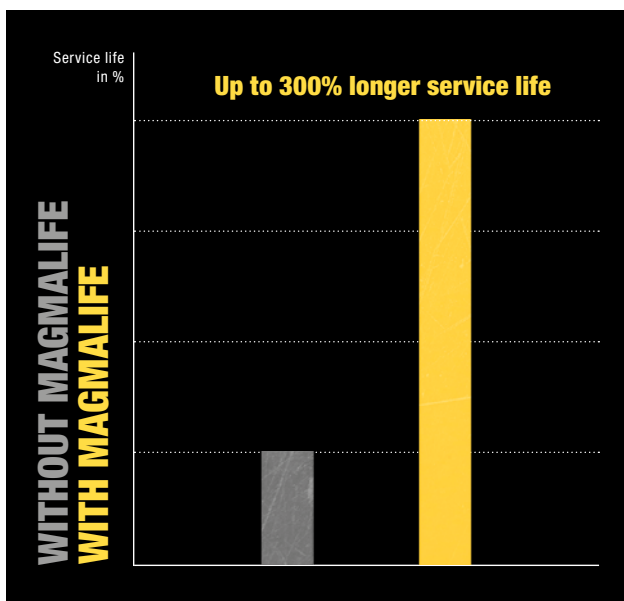

A significant increase in service life.

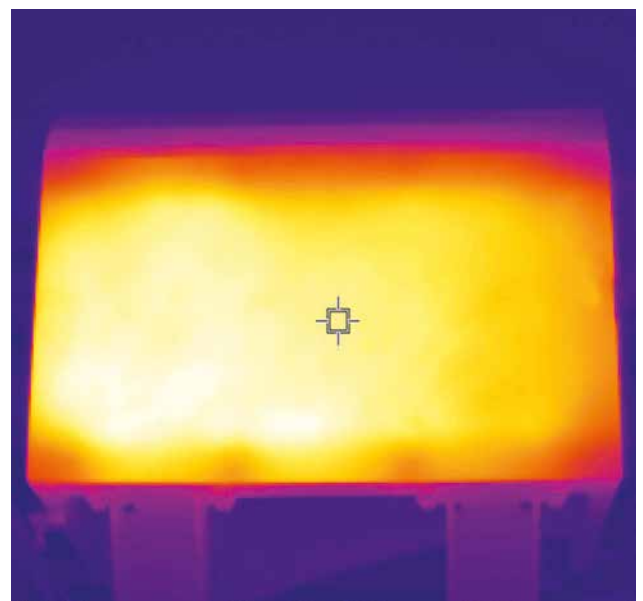

Optimal temperature distribution.

FOR PRECISE RESULTS:

## THE MATERIAL FLOW MAKES ALL THE DIFFERENCE.

A uniform feed of material in front of the screed is an important factor for oscillating behaviour, but it is also crucial for perfect evenness. The optimally-dimensioned auger of the BF 200 C-2 distributes the material perfectly in front of the screed; it can be controlled and reversed separately and prevents material segregation even with large paving widths. The control of the auger by ultrasonic sensors en-

sures even and appropriate material distribution in front of the screed. The powerful hydraulic drives always have adequate reserves, but can still be finely adjusted. And if something needs to be serviced, all auger blades can be replaced individually. This saves time and money. And increases availability.



Generously dimensioned hopper.



Perfect material distribution.



Optional: hydraulic hopper wings.





## MAINTENANCE WITH A CONCEPT:

# SIMPLE IS SIMPLY THE BEST.

The maintenance of the BF 200 C-2 is as simple as its operation. As every function is controlled by its own switch, every switch can also be replaced separately. Thanks to wide-opening doors, the engine compartment with the hydraulic systems is easily accessible from every side and all the filters can be reached comfortably and centrally from one side. The rotating parts are secured behind a

grille to prevent hands from getting too close to them. Good ideas such as the central lubrication points help to keep the maintenance intervals of the BF 200 C-2 remarkably long. Selected maintenance and emergency kits ensure extremely short downtimes when servicing is required.



Our employees have a solution for any problem.



All you need for maintenance: BOMAG Service Kits.



All you need in case of emergency: BOMAG emergency kits.



Standard features: easy access to maintenance points and protection against rotating parts thanks to a grille.





Fast, precise, robust – that’s how our QUICK COUPLING technology is best described. It is a perfect example of how our engineers think: brilliantly simple rather than simply complicated. And that’s what counts on the construction site.





## TYPICAL BOMAG: QUICK COUPLING.

# EQUIPPED WITH SHORT SET-UP TIMES.

Fast, simple, perfect: That's what BOMAG's QUICK COUPLING stands for. A smart quick attachment system, which allows screed extension without fiddly positioning. The result: a simple and labour-saving assembly that anyone can carry out on the construction site. This means shorter changeover times, which in turn significantly reduce costs. The use of sliding couplings makes it easy to connect the tamper and vibrating drive. Even with extensions and side plate installed, the transport dimen-

sions never exceed 2.5 m. Yet, it provides even more versatility of use: Only BOMAG offers a paving width of 0.4–3.4 m. That sets a benchmark.

The bottom line is: equipping the machine with intelligent technology solutions means higher productivity, because not a single minute of work time is wasted on the construction site or when transporting from one location to another.



Maximum flexibility, few parts, fast assembly.



Brilliantly simple: the receptacle of the QUICK COUPLING system.

## PAVING WIDTHS FOR ANY CONSTRUCTION SITUATION

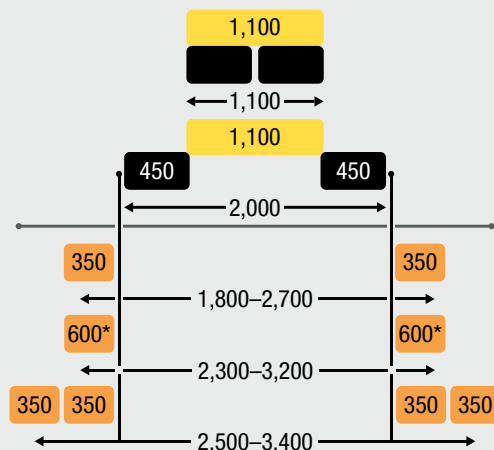

\* only for TV screeds

- Basic width retracted 1.1 m
- Basic width extended 2.0 m
- Max. working width with attachments 3.4 m
- Min. width with reduction shoes 0.4 m
- Max. paving thickness 0.2 m
- Levelling plate thickness 10 mm
- MAGMALIFE heating
- Crown profile -2% to +4%
- Vibration frequency 0–60 Hz
- Tamper vibration frequency 0–max. 30 Hz



TYPICAL BOMAG: ECOMODE.

## SMARTER UNDER THE HOOD.

With the ECOMODE concept, BOMAG can offer its customers what are surely the most efficient pavers on the market. As an active engine and hydraulic management system, ECOMODE has a positive effect everywhere:

with optimum power combined with low noise levels, reduced fuel consumption and CO<sub>2</sub> emissions. Make impressive progress while responsibly protecting your drivers' hearing and the environment – very much in keeping with the times. This is all thanks to ECOMODE's smart

working principle. Put simply: The system's variable displacement motor pump is self-regulating, meaning that only the power that is actually required is called up at any time. All functions are supplied with exactly the right power for the respective construction site requirements. The result is an impressively high degree of energy efficiency.

Especially in inner-city applications, it becomes clear that the BF 200 C-2's environmentally-friendly performance is a real asset.

ECOMODE technology also means the machine is quieter. Something everyone likes to hear especially when work is performed in urban areas.





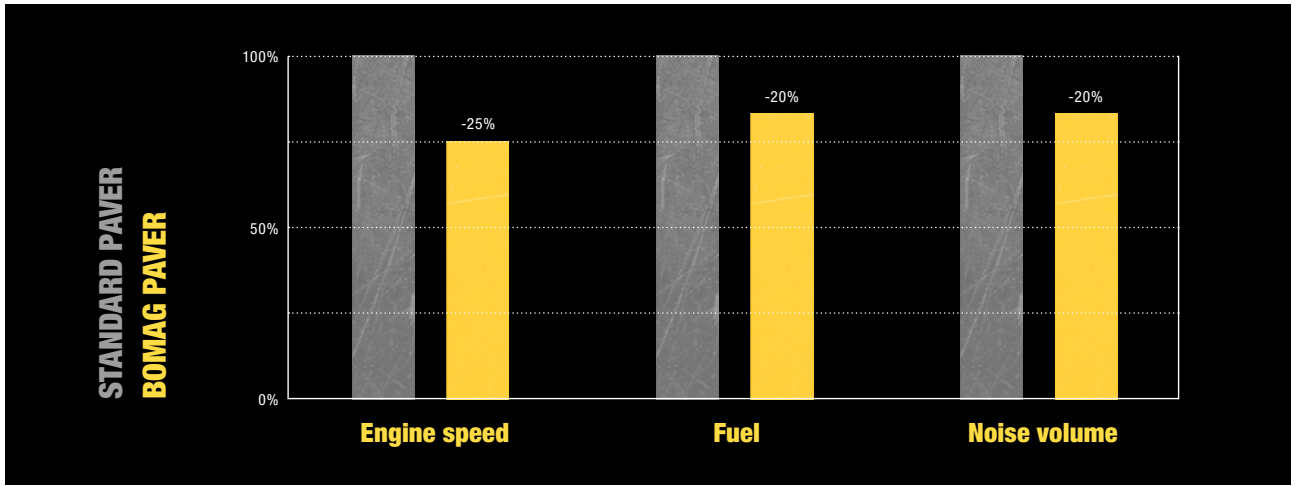

ECOMODE stands for excellent system layout.



Robust drive train in any operating conditions ...

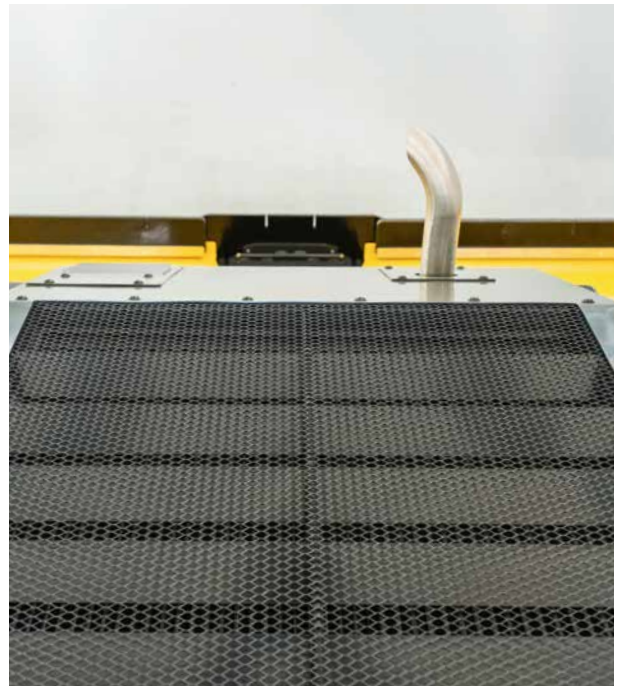

... thanks to the generous dimensions of the radiator.





## TYPICAL BOMAG: SIDEVIEW.

# ALWAYS KEEPING AN OVERVIEW.

What makes all our pavers outstanding also applies to the BF 200 C-2: our engineers' focus on comfort, ergonomics and ease of use. The result is the BOMAG 2-platform concept.

It systematically follows the formula "more work comfort = better work results". First of all, this is due to the fact that the operator's platform is easy to reach. Secondly, our 2-platform concept combines an excellent overview with compact dimensions.

In its upper position, the height-adjustable platform provides a full view of the hopper, the working area and the paver's working environment. All of this increases safety and improves communication within the team. The low platform position is ideal for applications where space is particularly limited. In this case, the machine 'shrinks' – to a height of less than 2 m. Even when the hopper is completely open, the viewing tunnels on both sides provide a view of the chain, dipstick and ground. This is a unique

feature in this class. The control panel can be quickly adjusted to the respective position. Indeed, the concept allows for very flexible operation – be it alone or in a team. This is courtesy of the adjustable screed control panels and the dual joystick (left and right) for operating the tractor. A USB port and storage space for a smartphone round off the well-thought-out concept.



Everything at a glance: good visibility in the entire working area.



Ease of operation in every situation.





Clear all-round view.



This is thanks to the viewing tunnel which allows a full view of the track drive and dipstick.



Low position: perfect for extremely confined spaces.



High position: complete overview of the machine.

FOR HIGHEST PRE-COMPACTION:

## THIS IS HOW COMPACTION REALLY WORKS.

The pre-compaction of BOMAG high-performance screeds is the combined result of tamper frequency, screed plate vibration and, of course, BOMAG's more than 60 years of experience. Up to 90% pre-compaction can be achieved – and all this with the standard screed, a unique feature compared to its competitors. The level of pre-compaction can be individually adjusted by controlling the frequencies of the tamper bar and the vibration units. However, the

decisive factor for the end result, i.e. uniform final compaction, is not only the level of pre-compaction. Equally important is its uniformity across the entire screed width. Both factors combined determine the evenness quality – and this is precisely one of the BF 200 C-2's greatest qualities.

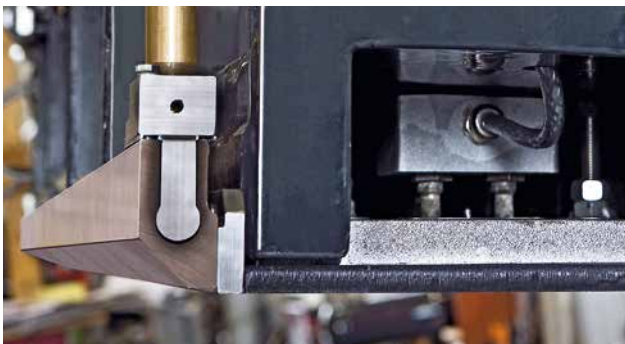
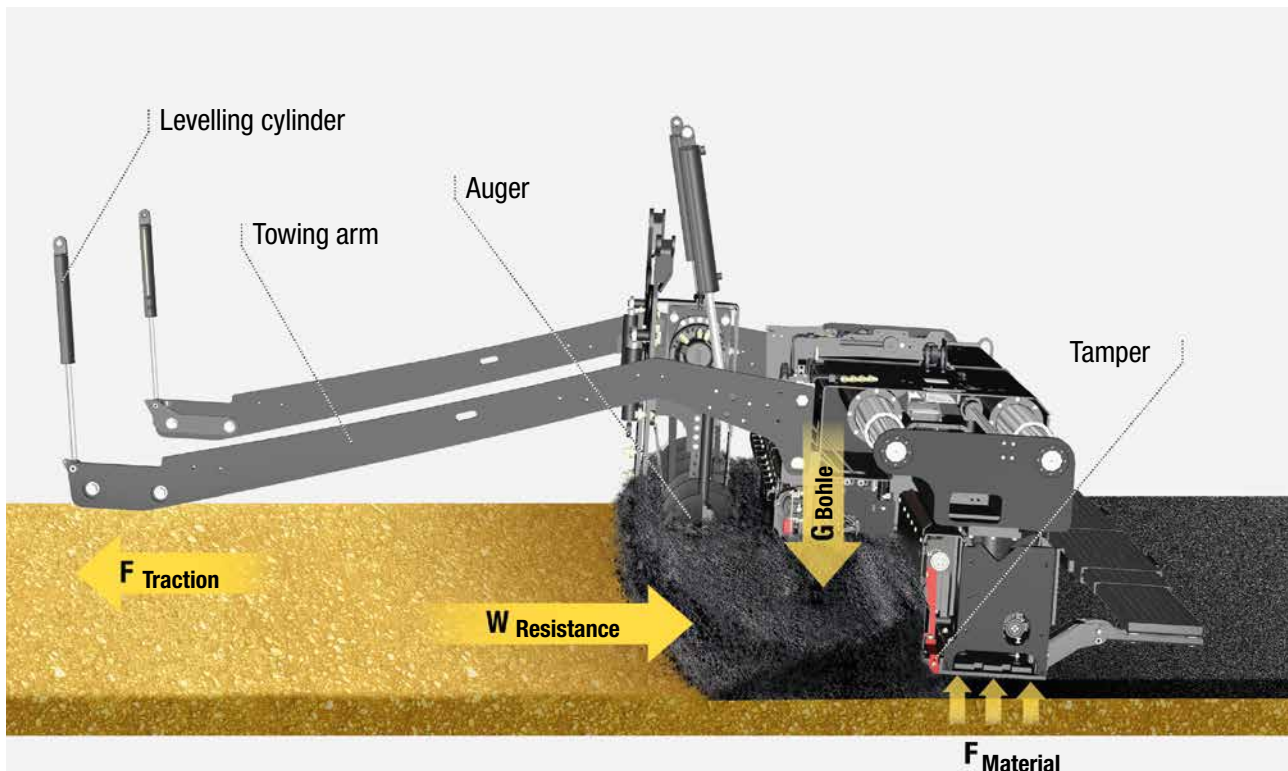

The best materials for consistently high pre-compaction.



Deep screed plates for perfect evenness.



FOR PERFECT EVENNESS:

## THINKING AHEAD, SO EVERYTHING RUNS SMOOTHLY LATER.

Perfect evenness of the asphalt surface is the declared goal of your work. To make this a reality, we devoted a lot of thought to it, right from the very first drawing. For example, we ensured the optimum weight distribution of the robust BOMAG high-performance screed, whose stable running properties ensure a perfect asphalt surface even when paving is interrupted. Its enormous self-

supporting capacity and rigidity make paving widths up to 3.4 m possible without supports. The screed plates are not only generously dimensioned, but also made of highly wear-resistant steel in a manufacturing process that allows the highest precision. When it comes to outstanding evenness and a perfect surface structure, we at BOMAG leave nothing to chance.



Perfect evenness.

### Key data of BOMAG high-performance screeds:

- Basic width retracted 1.1 m
- Basic width extended 2.0 m
- Max. working width 3.4 m
- Min. width with reduction pads 0.4 m
- Max. paving thickness 0.2 m
- Levelling plate thickness 10 mm
- MAGMALIFE heating
- Crown profile -2% to +4%
- Tamper frequency 0–max. 30 Hz

FOR PERFECT PAVING:

## HIGHLY MANOEVRABLE, EXTREMELY POWERFUL.

The BF 200 C-2's hydrostatically driven track chain ensures the necessary stability on construction sites where space is tight on both sides. This drive system combined with the interaction of chain motors and hydraulic pumps ensures dead straight paving and a high tractive force at

the same time. The chains make the BF 200 C-2 not only extremely efficient, but also highly manoeuvrable. Maintenance also requires very little effort. Thanks to the chain scrapers and the hydraulic track chain tensioners, the maintenance requirements are very low.



Chain scrapers guarantee low maintenance.



Long crawler tracks ensure dead straight paving.



Individually controllable chains allow turning in the tightest of spaces.





BF200III



MAGMA LIFE



OPTIONAL EQUIPMENT:

## WE BUILD THE BF 200 C-2 TO YOUR REQUIREMENTS.

*Although the BF 200 C-2 leaves the factory with everything needed for operation, as a customer you have plenty of scope to create your idea of the perfect machine.*



### SPECIAL PAINTWORK

Highly individual: customised paint job to give your fleet a uniform look.

### BOMAG TELEMATIC

Highly transparent: All machine data is permanently available for optimum fleet and service management. AEMP 2.0 standard-compatible.

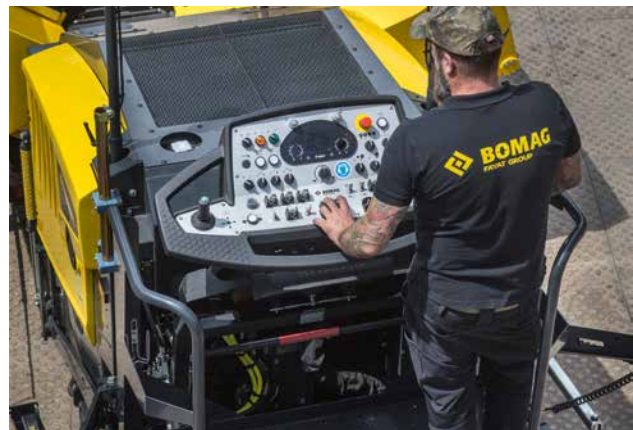

### HYDRAULIC HOPPER SIDE CONTROL

Very convenient: Hydraulic cylinder adjustment of the hopper side wall enables maximum feeding flexibility – straight from the driver's seat.

### CONVENIENT DRIVER'S STAND

Very easy to use: hydraulically height-adjustable driver's stand with adjustable control panel for maximum functionality with compact dimensions.





#### **EXTRACTION SYSTEM FOR ASPHALT FUMES**

Great relief: Asphalt fumes are extracted by the system directly at the tunnel and returned to the hopper.



#### **ON-BOARD CLEANING KIT**

Especially thorough: electrically driven pump with hose and spray gun for thorough cleaning of the paver.





## NEEDS LITTLE SPACE TO SET THE STANDARD.

Compact, convenient, uncompromising: Wherever you use the BF 200 C-2, you can rely on its outstanding qualities. It is as robust as a large paver, but also as compact as a mini paver should be.

It is easy to use: quiet, manoeuvrable, powerful, and just as easy to operate as it is to maintain and service. And

when it comes to achieving a perfect paving result, the BF 200 C-2 is all the more uncompromising thanks to its screed technology.

With BOMAG's more than 60 years of expertise behind you, you can face any challenge with confidence.





	<b>BF 300 C</b>	<b>BF 200 C</b>
Weight	8.8 t	6.0 t
Hopper size	4.8 m <sup>3</sup>	2.2 m <sup>3</sup>
Engine	55.4 kW Kubota	55.4 kW Kubota
Exhaust classification	Stage V/TIER 4f	Stage IIIa/TIER 3 Stage V/TIER 4f
Screed type	S 340-2 TV	S 200 TV
Compaction unit	Tamper vibration	Tamper vibration
Standard paving width	1.7–3.4 m	1.1–2.0 m
Maximum paving width	5.0 m	3.4 m

Mini pavers and city pavers compared.

FOR THE DIGITAL CONSTRUCTION SITE.

## **KNOW EVERYTHING – REALLY EVERYTHING.**

Our machines with intelligent measuring technology are the prerequisite for digitising the construction site. To achieve this comprehensive transparency, BOMAG has combined a whole range of modules into an integrated solution. Our solutions work hand in hand – fully digitally.

With BOMAG TELEMATIC, you are always 100% up-to-date in real time, comprehensively and globally. All of your machinery fleet activities are fully transparent. This offers you considerable advantages in fleet management when it comes to resource planning, service and safety.

All important machine information as well as productive data can be recorded via our JOBLINK interface. As a team, Joblink and BOMAP provide the highest level of quality assurance and qualified records.

BOMAP, the smart helper on the construction site, is the new, self-explanatory mobile solution that allows you to document your work results on the job in real time. BOMAP Connect links the machines together to create a complete compaction map of the construction site – across all machines, even from different manufacturers.

ASPHALTPRO, the third element of digital networking, can be linked to BOMAP data. This allows you to see at any time and at any position on the site which material has been placed where with which batch, which roller has compacted it as well as its temperature and the measuring values achieved. The result is a transparent construction site.

Thanks to this unique link, BOMAG is the only company that can map and document everything from planning to the finished compacted asphalt in real time.

The right machine, with the right personnel, on the right construction sites at the right time – BOMAG TELEMATIC and BOMAG Resource Manager make sure of this. The bottom line is simple: an end to the many planning tables and lists of different planning managers who all access the same resources. Thanks to BOMAG Resource Manager, the effort is kept to a minimum. All resources at multiple construction sites can be managed simultaneously with ease. This makes resource planning as flexible as required in practice.

- All operating hours always transparent
- All service data at a glance
- Unauthorised use (theft) detected at any time
- Also available as a retrofit solution





**BOMAG MACHINES.**  
THE GUARANTEE FOR  
YOUR SUCCESS.



**JOBLINK.**  
THE OPEN INTERFACE.

# 360° DIGITAL



**TELEMATIC.**  
THE EFFICIENT FLEET  
MANAGER.



**BOMAP.**  
THE SMART HELPER ON  
THE CONSTRUCTION SITE.



**ASPHALTPRO.**  
THE CONTROL CENTRE FOR  
ROAD CONSTRUCTION.



## QUALITY QUICKLY BECOMES EVIDENT.

Everywhere. It's really no surprise then that our machines are in use around the globe: on major projects, such as the construction of the motorway from Beijing to Inner Mongolia, or on more immediate tasks like renovating

an inner-city pedestrian walkway. In both cases, delivering excellent results is key. This is what we stand for as your technology and service partner. Success always comes from teamwork.





